

PARTS LIST						
ITEM	QTY	PART NO.	PART DESCRIPTION	LENGTH	UNIT WT.	NET WT.
1	3	X-232696	BALLAST TRAY WELDMENT - SITE PRO 1		66.60	199.79
2	12	X-CSRT-PCB	PIPE CONNECTION BRACKET	12 in	3.01	36.08
3	3	X-CSRT-P3SP	3-1/2" SPLICE PIPE	8 in	5.11	15.32
4	8	X-CSRT-GP30	3" GUSSET PLATE	12 in	4.04	32.35
5	12	X-CSRT-TW	3-1/2" T-WELDMENT		4.93	59.12
6	2	X-CSRT-P3024	2-7/8" DIA. PIPE X 24" LONG	24 in	12.19	24.38
8	10	X-CSRT-P3072	2-7/8" DIA. PIPE X 72" LONG	72 in	36.81	368.07
9	3	X-CSRT-P3096	2-7/8" DIA. PIPE X 96" LONG	96 in	49.12	147.35
10	28	X-UB1300	1/2" X 3" X 5" X 2" U-BOLT (HDG.)		0.70	19.51
11	64	G1205	1/2" x 5" HDG HEX BOLT GR5 FULL THREAD	5 in	0.33	20.85
13	12	G1202	1/2" x 2" HDG HEX BOLT GR5	2 in	0.18	2.11
14	184	G12FW	1/2" HDG USS FLATWASHER	3/32 in	0.03	6.27
15	132	G12LW	1/2" HDG LOCKWASHER	1/8 in	0.01	1.84
16	132	G12NUT	1/2" HDG HEAVY 2H HEX NUT		0.07	9.45
TOTAL WT. #						942.50

**NOTES:**

1. CONCRETE BLOCKS (CMU), 4x8x16 OR 8x8x16, ARE TYPICALLY USED FOR BALLAST.

**TOLERANCE NOTES**  
 TOLERANCES ON DIMENSIONS, UNLESS OTHERWISE NOTED ARE:  
 SAWED, SHEARED AND GAS CUT EDGES (± 0.030")  
 DRILLED AND GAS CUT HOLES (± 0.030") - NO CONING OF HOLES  
 LASER CUT EDGES AND HOLES (± 0.010") - NO CONING OF HOLES  
 BENDS ARE ± 1/2 DEGREE  
 ALL OTHER MACHINING (± 0.030")  
 ALL OTHER ASSEMBLY (± 0.060")

PROPRIETARY NOTE:  
 THE DATA AND TECHNIQUES CONTAINED IN THIS DRAWING ARE PROPRIETARY INFORMATION OF VALMONT INDUSTRIES AND CONSIDERED A TRADE SECRET. ANY USE OR DISCLOSURE WITHOUT THE CONSENT OF VALMONT INDUSTRIES IS STRICTLY PROHIBITED.

DESCRIPTION  
**CONSTRUCTOR-SET ROOF TOP -  
 1 SIDED NON-PENETRATING, 12' FACE, 3 MASTS**

CPD NO.	DRAWN BY <b>BMC3</b>	6/8/2020	ENG. APPROVAL
CLASS <b>87</b>	SUB <b>02</b>	DRAWING USAGE <b>SHOP</b>	CHECKED BY



**A valmont COMPANY**

Locations:  
 New York, NY  
 Atlanta, GA  
 Los Angeles, CA  
 Plymouth, IN  
 Salem, OR  
 Dallas, TX

Engineering  
 Support Team:  
 1-888-753-7446

PART NO.	<b>CSRT-13-8128</b>	PAGE 1 OF 2
DWG. NO.	<b>CSRT-13-8128</b>	

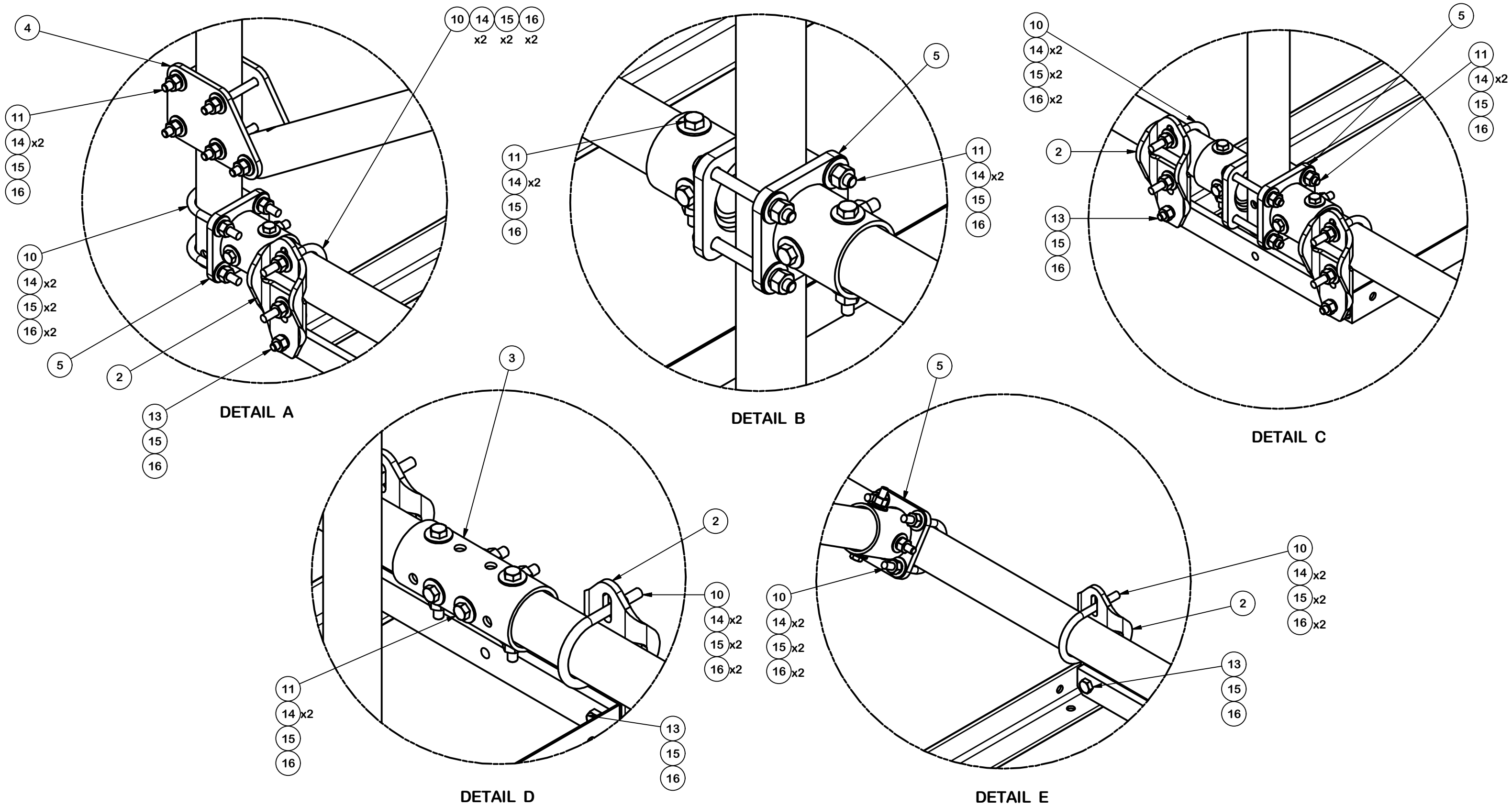

**TOLERANCE NOTES**

TOLERANCES ON DIMENSIONS, UNLESS OTHERWISE NOTED ARE:  
 SAWED, SHEARED AND GAS CUT EDGES ( $\pm 0.030''$ )  
 DRILLED AND GAS CUT HOLES ( $\pm 0.030''$ ) - NO CONING OF HOLES  
 LASER CUT EDGES AND HOLES ( $\pm 0.010''$ ) - NO CONING OF HOLES  
 BENDS ARE  $\pm 1/2$  DEGREE  
 ALL OTHER MACHINING ( $\pm 0.030''$ )  
 ALL OTHER ASSEMBLY ( $\pm 0.060''$ )

PROPRIETARY NOTE:  
 THE DATA AND TECHNIQUES CONTAINED IN THIS DRAWING ARE PROPRIETARY INFORMATION OF VALMONT INDUSTRIES AND CONSIDERED A TRADE SECRET. ANY USE OR DISCLOSURE WITHOUT THE CONSENT OF VALMONT INDUSTRIES IS STRICTLY PROHIBITED.

DESCRIPTION  
**CONSTRUCTOR-SET ROOF TOP -  
 1 SIDED NON-PENETRATING, 12' FACE, 3 MASTS**

CPD NO.	DRAWN BY <b>BMC3</b>	6/8/2020	ENG. APPROVAL
CLASS <b>87</b>	SUB <b>02</b>	DRAWING USAGE <b>SHOP</b>	CHECKED BY



Locations:  
 New York, NY  
 Atlanta, GA  
 Los Angeles, CA  
 Plymouth, IN  
 Salem, OR  
 Dallas, TX

Engineering  
 Support Team:  
 1-888-753-7446

PART NO.	<b>CSRT-13-8128</b>
DWG. NO.	<b>CSRT-13-8128</b>